



RIDERS

TABLE OF CONTENTS

BASIC RIDER	2-5
BACKLINE	6-7
FOH INPUT LIST	8
MONITOR MIX & LAYOUT	9
STAGE PLOT	10



BASIC RIDER 2019

GENERAL:

1. Backstage

PROMOTER agrees to supply one (1) comfortable, private dressing room/area near the stage for up to six (6) male band/cast members and one (1) comfortable, private dressing room/area near the stage for up to two (2) female band/cast members. **See Cast List for actual number.** Said dressing rooms shall be equipped with hand towels, a lighted mirror, blow dryer, clothes rack, dressing table, AC power and bathroom or bathroom nearby. Backstage shall also be supplied with basic catering consisting of deli tray, assorted nuts, fresh fruit and vegetables, chocolate candy (e.g. M&M's), bottled water, sparkling water, ice, diet and regular sodas, ginger ale, fruit juices, coffee, tea, 1/2 and 1/2, 2% milk, sugar, honey and lemon. Same catering will be provided for rehearsal and sound check.

2. Accommodations

PROMOTER agrees to supply one (1) non-smoking king room in a first class hotel at or near the venue for **PRODUCER/ARTIST** and six (6) non-smoking private king rooms for each band/cast member. Three (3) meals per day for **ARTIST/PRODUCER**, band and cast or agreed upon per diem. **See Rooming List for actual number.**

3. Transportation

PROMOTER agrees to supply round-trip airline transportation for **PRODUCER/ARTIST**, band and cast members from cities to be determined **unless other arrangements are made (See Performance Contract).**

PROMOTER agrees to supply all necessary ground transportation between airport, hotel and venue by a professional car service or other agreed upon transportation.

4. Miscellaneous

A four (4) hour sound check and technical rehearsal shall be provided on the day of the first performance, with full technical crew and AV.

When **ARTIST** is the headliner, **PRODUCER/ARTIST** must be informed of all acts appearing with them and shall have the sole right of approval of any and all acts and length of their performance.

When **ARTIST** is the headliner, **ARTIST** shall receive 100% sole headline billing in all advertising, lights, displays, programs, marquees, and any and all other advertising and publicity media.

ARTIST shall have the right to cancel the performance with Sixty (60) days' notice. In the case that **ARTIST** cancels the performance; the **PRODUCER/ARTIST** will return the 50% deposit in full.

CLIENT shall have the right to cancel the engagement however the 50% deposit will be retained by **PRODUCER/ARTIST**, if cancelled prior to 30 days from the date of the event. If cancelled within 30 days of the event, the **CLIENT** will be responsible for full payment.

For ticketed engagements, **PRODUCER/ARTIST** is to receive twenty (20) complimentary tickets per show.

For ticketed engagements, ABSOLUTELY NO ADVERTISING OF THIS ENGAGEMENT CAN BE MADE UNTIL A 50% DEPOSIT IS PAID WITHOUT PRIOR WRITTEN APPROVAL OF **PRODUCER/ARTIST**.
Billing of show shall be:

ADVENTURES IN PARROTDISE

A Tribute to Jimmy Buffett
starring
Barrie Cunningham
The Lost Shaker Band & the
Island Girls

HOT AUGUST NIGHTS

A Tribute to Neil Diamond
starring
Barrie Cunningham
The Hot August Nights Band & the
Diamond Girls

1. with an industry standard operator for the lighting board for each performance.
2. PURCHASER agrees to supply a first class sound system capable of producing an unequalized frequency response +/- 3dB 50Hz to 16kHz at an undistorted signal of 120 dB SPL at the front of house console in any venue. PURCHASER also agrees to provide industry standard sound engineers for front of house and monitor consoles.
 - A. House system must include four (4) wireless vocal handheld microphones and receivers, one (1) for PRINCIPAL ARTIST, two (2) for background vocalists and one (1) spare, prefer Shure Beta 87C, Shure Beta 58 or equivalent, one (1) wireless system with body pack for PRINCIPAL ARTIST's acoustic guitar, and sufficient microphones, stands and cables to individually mic drums, electric guitar, 2 keyboards and bass guitar. Wired mics are acceptable if wireless are unavailable.
 - B. House system should be equipped with 1/3 octave equalization for all sends and an industry standard effects processor with monitor send.
 - C. Monitor system must include separate mixes for each mic or line in. Minimum of Eight (8) monitor wedges with seven (7) mixes in addition to reverb and effects or other approved by artist.
 - D. House system must include capability for front of house playback with monitor send for house music and tracks.
3. PURCHASER agrees to supply the following equipment with sufficient power supply, power strips, and extension cords:
 - A. Amps, keyboards and other accessories.
4. PURCHASER agrees to supply ALL BACKLINE to include industry standard drum kit, bass amp and speaker cabinet, guitar amp(s), keyboard amp and two (2) keyboards. SEE BACKLINE RIDER.
5. PURCHASER agrees to supply a stage or portable stage at minimum dimensions of 36'(wide) X 24' (deep) X 36" (high). In addition, PURCHASER agrees to supply a stage riser for the drums, minimum dimensions of 8' X 8' X 18", and two (2) 8' X 8' X 12" risers, one for background vocalists and one for keyboards. Or other approved by artist/producer.

1. dance floor, partitions, etc.) **unless approved by PRODUCER/ARTIST prior to concert or show.**

PRODUCER/ARTIST’S MERCHANDISE

The Purchaser will provide a well lit secure place to sell merchandise. Purchaser shall provide one (1) four (4’) table and a tent/canopy for any outdoor shows. This shall be in such a position as to be easily visible to the public using the main entrance. This is to be at no cost to the Producer/Artist. Purchaser agrees that its arrangement for presenting the engagement provided for herein shall prohibit the sale of bootleg souvenir or similar merchandise on the premises in connection with this engagement other than Producer/Artist’s official merchandise furnished by Producer/Artist. The Purchaser and/or venue cannot sell or manufacture any items with **SHOW** logo or any facsimile, name or likeness **without prior written permission** from Producer/Artist or his authorized representative. Producer/Artist is to retain 100% of the gross receipts resulting from the sale of Producer/Artist merchandise.

AGREED AND ACCEPTED BY:

AGREED AND ACCEPTED BY:

PURCHASER

DATE

ARTIST/PRODUCER

DATE

WILLIAM BARRIE CUNNINGHAM
 SUPERSTAR TRIBUTES LLC
 3670 Saint Nazaire Ave.
 Las Vegas, NV 89141
 702.443.5271
bcenter2@aol.com
www.superstartributes.com

BACKLINE AIP **2019**

Keyboards

Keyboards – Steve

Bottom Keyboard

- One Yamaha Motif XF 88 or Montage Keyboard
- One Yamaha sustain pedal
- One Yamaha FC 7 expression pedal

Top Keyboard

- Kong Triton Extreme 76 key. 61 key will work, prefer 76 key.
- One two tier stand – heavy duty
- One sustain pedal
- One tall stool
- One music stand w/light - heavy duty

The producer must approve all substitutions

Guitar Amps (2)

- 1 - Fender Blues DeVille 2 X 12's or Fender Twin 2 X 12's
- 1 - Fender Twin 2 X 12's

Miscellaneous

- 1 - Music stand w/light
- 3 – Guitar stands...2 electric and 1 acoustic
- The producer must approve all substitutions

Bass Guitar Amps and Heads

- First Choice:
Gallien - Kruger 800RB head with a Hartke 410 cabinet
- Second Choice:
SWR with similar configuration
- Third Choice:
Ampeg SVT for very large/loud shows

Miscellaneous

- 1 - Music stand w/light
- 1 – Guitar stand
- The producer must approve all substitutions

Drums

Drum Kit - DW with maple shells or Gretsch Catalina with maple shells

- 1 - Bass drum. Standard 22" with Evans E-Mad, Remo Powerstroke or Aquarian Super Kick heads
- 2 - Rack toms. 10" and 12" with Evans G2 (clear) or Remo Pinstripe heads
- 2 - Floor toms. 14" and 16" on legs with Evans G2 (clear) or Remo Pinstripe heads. No floor toms on stands!
- 1 - Snare drum. 14" x 5 ½", 10 and 6 maple with Remo Ambassador coated heads
- 1 - Snare drum spare. 14" x 5 ½", wood or metal with Remo Ambassador coated heads

Hardware

- 4 - Double braced boom cymbal stands. DW 9000 series
- 1 - Hi-hat stand. 2 leg DW 9000 series
- 1 - Single pedal. Chain drive DW 9000 series

Cymbals

- Zildjian A Custom or Sabian AA series
- 1 - 20" ride
- 1 - 16" crash
- 1 - 18" crash
- 2 - 14" hi-hat
- 1 - 12" splash

Miscellaneous

- 1 - Music stands w/light
- 1 - Cow Bell and clamp
- The producer must approve all substitutions

BGV (Background Vocalists #1, #2)

- 2 – High Stools
- 1 – Music stand w/light

FOH INPUT LIST AIP

SNAKE CH.	FOH CH.	FOH INPUT	MIC	FOH INSERT	Sub Snake	Stand
1	1	KICK	SM-91	GATE	A-1	
2	2	KICK	Beta 52	COMP & GATE	A-2	
3	3	SNARE TOP	SM-57	COMP & GATE	A-3	
4	4	SNARE BOT	Beta 56	GATE	A-4	
5	5	HAT	SM-81		A-5	
6	6	RK TOM-1	SEN 604	GATE	A-6	
7	7	RK TOM-2	SEN 604	GATE	A-7	
8	8	FLOOR TOM-1	SEN 604	GATE	A-8	
9	9	FLOOR TOM-2	SEN 604	GATE	A-9	
10	10	OVHD (SR)	SM-81		A-10	
11	11	OVHD (SL)	SM-81		A-11	
12	12	RYDE	SM-81		A-12	
13	13	KEYS-1 L	DI	COMP	B-1	
14	14	KEYS-1 R	DI	COMP	B-2	
15	15	KEYS-2 L	DI	COMP	B-3	
16	16	KEYS-2 R	DI	COMP	B-4	
17	17	E GTR1	SM-57	COMP	B-5	SM BOOM
18	18	BASS	DI	COMP	B-6	
19	19	ACC GTR		COMP	RF-1	BODY PACK
20	20	E GTR2	SM-57	COMP	B-7	SM BOOM
21	21					
22	22					
23	23	DRUM VOX	SM-58	COMP	C-1	TALL BOOM
24	24	KEYS VOX	SM-58	COMP	B-8	TALL BOOM
25	25	E GTR1 VOX	SM-58	COMP	B-9	TALL BOOM
26	26	BASS VOX	SM-58	COMP	B-10	TALL BOOM
27	27					
28	28	L.VOX	SM-87C	COMP	RF-2	TALL BOOM
29	29					
30	30					
31	31					
32	32					
33	33	BG VOX 1	SM-87C	COMP	RF-3	TALL STAND
34	34	BG VOX 2	SM-87C	COMP	RF-4	TALL STAND
35	35	SP VOX	SM-87C	COMP	RF-5	
36	36					
37	37	VOX VERB L				
38	38	VOX VERB R				
39	39	VOX DELAY L				
40	40	VOX DELAY R				
41	41	DRUM VERB L				
42	42	DRUM VERB R				
43	43	DELAY				
44	44	TALK BACK				
45	45	VIDEO				
46	46	CD L				
47	47	CD R				

MONITOR MIX & LAYOUT

Monitor Mixes

1. Lead Vocal (LV) - DSC - 2 wedges
2. Keys - USL - 1 wedge
3. Guitar - SR - 1 wedge
4. Bass – SL - 1 wedge
5. Drums - USC – 1 wedge
6. Background Vocal (BGV #1) – USR - 1 wedge
7. Background Vocal (BGV #2) – USR - 1 wedge
8. 2 - Sidefills (Mono) Optional
9. SPX 1
10. SPX 2

Cue - 1 wedge

Spare - 1 wedge

Total Stage Wedges - 10

Sidefills – 2 Optional

Two reverbs (SPX990 or equivalent).

All outputs are subject to change.

DSC = Downstage Center

DSL = Downstage Left

DSR = Downstage Right

USC = Upstage Center

USL = Upstage Left

USR = Upstage Right

STAGE LEFT

DOWN STAGE

STAGE RIGHT

SF
I I
DL
EL

SF
I I
DL
EL

STAGE PLOT

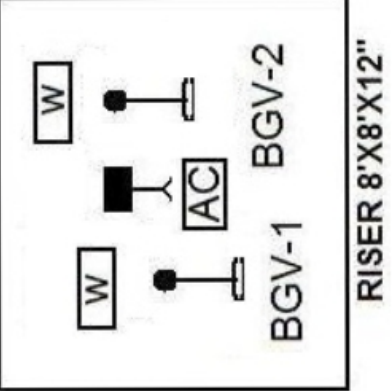
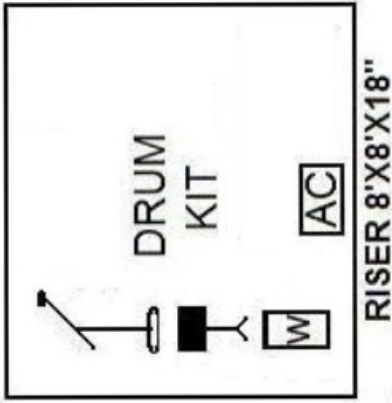
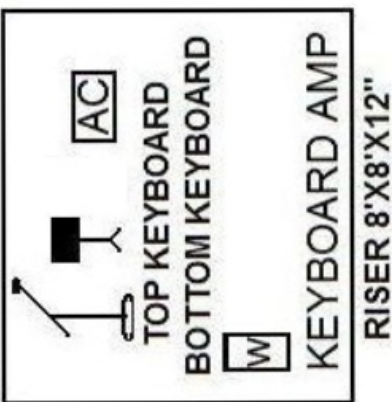
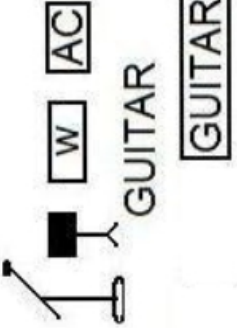
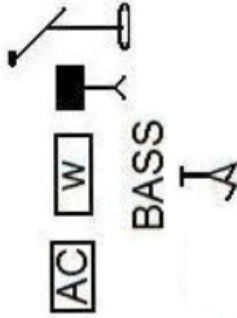

- = GUITAR STAND
- = MUSIC STAND W/LIGHT
- = TALL STAND

- = BOOM STAND
- = POWER
- = WEDGE

ADVENTURES IN PARROTIDISE
 4 PC BAND, 1 LEAD VOCAL (LV) AND
 2 BACKGROUND VOCALS (BGV)
 BARRIE CUNNINGHAM, PRODUCER
 702.443.5271 CELL
 BCENTER2@AOL.COM